

Quartz Crystal Theory

What is Quartz

The technical formula is SiO_2 and it is composed of two elements, silicon and oxygen. In its amorphous form SiO_2 is the major constituent in many rocks and sand. The crystalline form of SiO_2 or quartz is relatively abundant in nature, but in the highly pure form required for the manufacture of quartz crystal units, the supply tends to be small.

The limited supply and the high cost of natural quartz have resulted in the development of a synthetic quartz manufacturing industry. Synthetic quartz crystals are produced in vertical autoclaves. The autoclave works on the principle of hydrothermal gradients with temperatures in excess of 400°C and pressures exceeding 1,000 atmospheres. Seed quartz crystals are placed in the upper chamber of the autoclave with natural quartz (lascas) being placed in the lower chamber. An alkaline solution is then introduced which when heated increases the pressure within the chamber. The autoclave heaters produce a lower temperature at the top chamber in comparison to the bottom. This temperature gradient produces convection of the alkaline solution which dissolves the natural quartz at the bottom of the chamber and deposits it on the seed crystals at the top. Alpha crystals produced by this method can have masses of several hundred grams and can be grown in a few weeks. If the temperature reaches 573°C a phase transition takes place which changes the quartz from an alpha to a beta (loss of piezoelectric property).

Quartz crystals are an indispensable component of modern electronic technology. They are used to generate frequencies to control and manage virtually all communication systems. They provide the isochronous element in most clocks, watches, computers and microprocessors. The quartz crystal is the product of the phenomenon of piezo-electricity discovered by the Curie brothers in France in 1880.

Why it works

Piezoelectricity is a complex subject, involving the advanced concepts of both electricity and mechanics. The word piezo-electricity takes its name from the Greek piezein "to press", which literally means pressure electricity. Certain classes of piezo-electric materials will in general react to any mechanical stresses by producing an electrical charge. In a piezoelectric medium the strain or the displacement depends linearly on both the stress and the field. The converse effect also exists, whereby a mechanical strain is produced in the crystal by a polarising electric field. This is the basic effect which produces the vibration of a quartz crystal.

Quartz resonators consist of a piece of piezoelectric material precisely dimensioned and orientated with respect to the crystallographic axes. This wafer has one or more pairs of conductive electrodes, formed by vacuum evaporation. When an electric field is applied between the electrodes the piezoelectric effect excites the wafer into mechanical vibration. Many different substances have been investigated as possible resonators, but for many years quartz has been the preferred medium for satisfying the needs for precise frequency generation. Compared to other resonators e.g. LC circuits, mechanical resonators, ceramic resonators and single crystal materials, the quartz resonator has proved to be superior by having a unique combination of properties. The material properties of quartz crystal are both extremely stable and highly repeatable. The acoustic loss or internal fraction of quartz is particularly low, which results in a quartz resonator having an extremely high Q-factor. The intrinsic Q of quartz is 10^7 at 1 MHz. Mounted resonators typically have Q factors ranging from tens of thousands to several hundred thousands, orders of magnitude better than the best LC circuits. The second key property is its frequency stability with respect to temperature variations.

Aging of the quartz (fig.1) resonator is related to the stability of its mechanical components. Short and long term stability manifests in frequency drifts of only a few parts per million per year and are readily available even from commercial units. Precision crystal units manufactured under closely controlled conditions are only second to atomic clocks in the frequency stability and precision achieved.

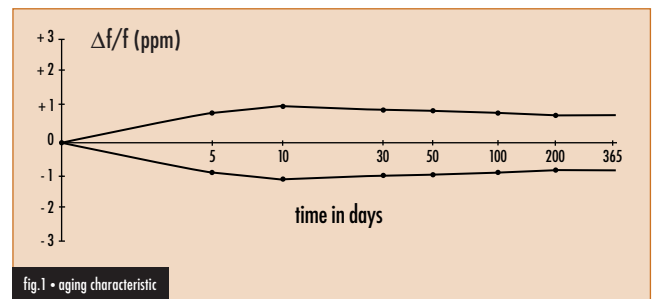

fig.1 - aging characteristic

What makes quartz so important

The AT-cut characteristic (fig.2) is the most commonly used type of resonator. It has a frequency temperature coefficient described by a cubic function of temperature, which can be precisely controlled by small variations in the angle of cut. This cubic behaviour is in contrast to most other crystal cuts which give a parabolic temperature characteristic. It makes the AT-cut well suited to applications requiring a high degree of frequency stability over wide temperature ranges. Other important characteristics are aging and quality factor Q.

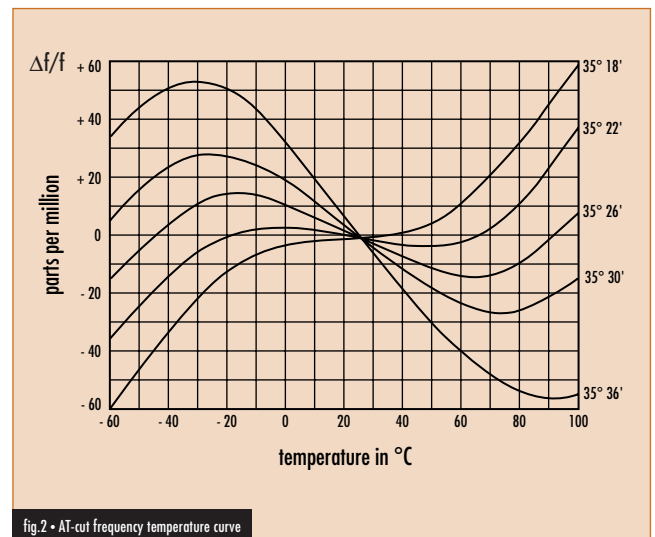

fig.2 - AT-cut frequency temperature curve

Quartz Crystal Theory

Modes of vibration, cuts and frequency ranges

The AT-cut resonator uses the thickness shear mode of vibration (fig.3). A standing wave is set up in the crystal blank by the reflection at both major surfaces of traverse waves travelling in the thickness direction. The major mechanical displacement is in the plane of the crystal at right angles to the direction of wave propagation. At resonance an odd number of half wave lengths are contained in the thickness plane of the crystal blank. Therefore the thickness is the primary frequency determining dimension.

The AT-cuts (fig.5) are commonly manufactured in the frequency ranges:

- 1 MHz ~ 32 MHz as fundamental
- 30 MHz ~ 250 MHz as overtone (3rd; 5th; 7th; 9th)

Below about 1 MHz the thickness shear mode resonators become too cumbersome and unwieldy for general use and other modes of vibrations are used:

- a) below about 100 kHz flexural, length extensional mode
- b) 100 kHz face shear, CT; DT; SL cuts (fig.6)

For each mode of vibration there is an optimal angle of cut which controls the frequency deviation of the quartz crystal over the temperature range.

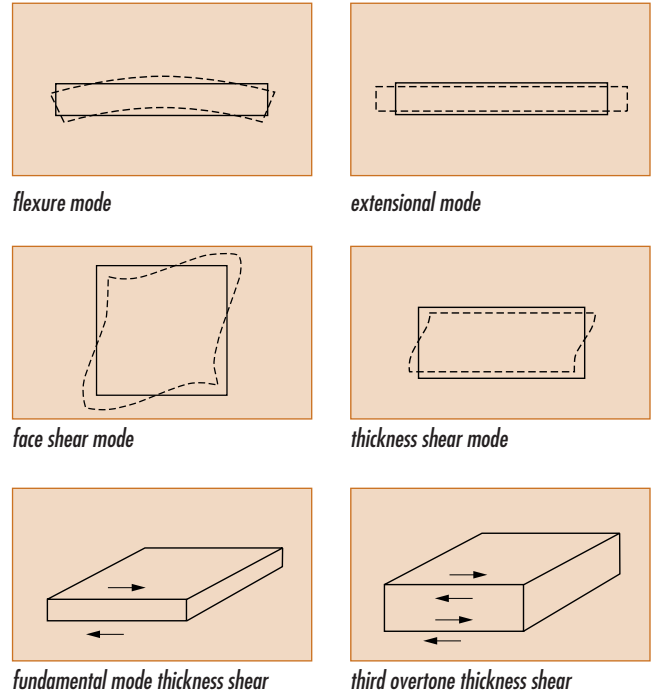

fig.3 • Modes of vibration

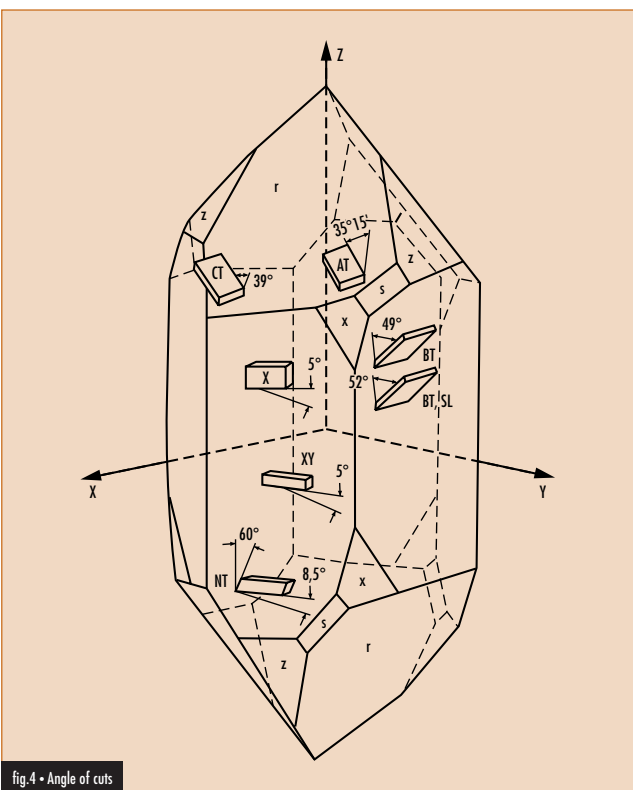

fig.4 • Angle of cuts

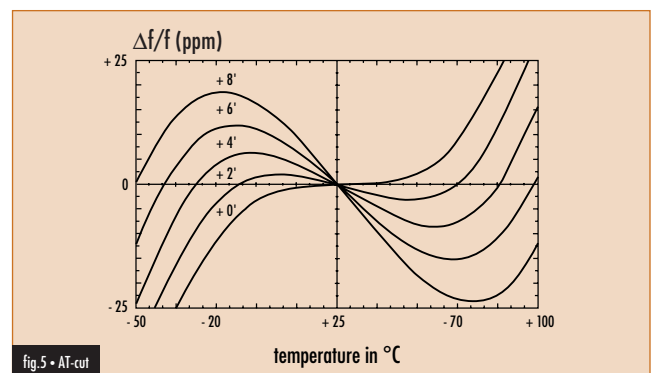

fig.5 • AT-cut

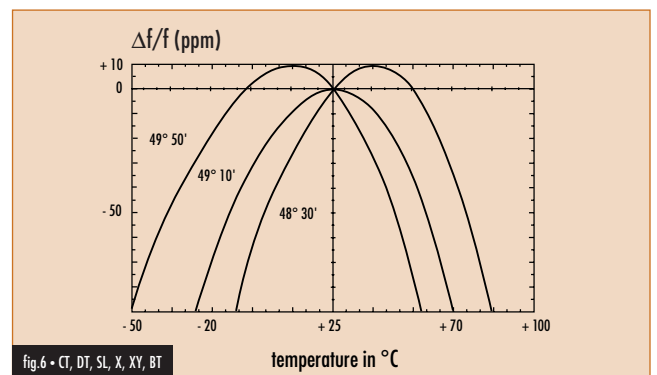

fig.6 • CT, DT, SL, X, XY, BT

Quartz Crystal Theory

Manufacturing of quartz crystals

1. cutting (sawing) the wafers (fig.7)
2. lapping the wafers
3. cleaning the wafers
4. checking the orientation of wafers (X-ray measurement)
5. rounding the wafers (now called blanks)
6. cleaning and etching of the blanks
7. base plating (vacuum deposition of electrodes - silver or gold)
8. mounting (fitting the crystal resonator into the holder) bonding (silver-epoxy bonding point to connect the crystal electrode to the holder)
9. final adjustment of the frequency by vacuum deposition of silver or gold)
10. sealing the holder to the can (resistance weld or cold weld under dry nitrogen atmosphere), preventing electrode oxidation

Other processes during the manufacturing phases are:

- cleaning
- high temperature cycling
- high vacuum bake cycling
- frequency control and sorting

The cleanliness of the parts, the carefully designed and produced crystal blanks, the minimum stress on the resonator and the inclusion of a dry nitrogen atmosphere in a hermetically sealed package are all very important for the production of stable and high quality quartz crystals.

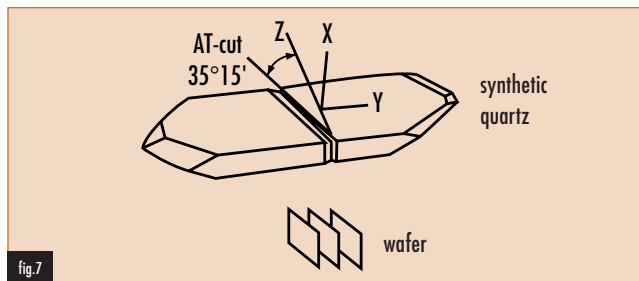

fig.7

Equivalent circuit

Fig.8 shows the conventionally accepted equivalent circuit of a crystal at a frequency near its main mode of vibration. The L_1 , C_1 , R_1 are known as the motional parameters of the crystal. The element C_0 represents the shunt capacitance resulting from stray capacitance between the terminals and capacitance between the electrodes. It can be measured as the effective capacitance of the crystal unit at frequencies far removed from resonance. It is known as static capacitance. L_1 , C_1 , R_1 are the electrical equivalents to the inertia, stiffness and internal losses of the mechanical vibrating system. The Q value of the motional arm as compared to the LC circuit is extremely high (50'000 ~ 500'000).

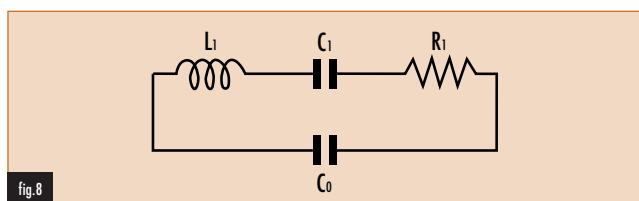

fig.8

Precise analysis of the equivalent circuit reveals several characteristic frequencies. In most practical cases, because of the very high resonator Q , it is sufficient to consider only two frequencies - the series and parallel resonant frequencies.

series resonant frequency:

$$f_s = \frac{1}{2\pi \cdot \sqrt{L_1 C_1}}$$

1

parallel resonant frequency:

$$f_p = \frac{1}{2\pi \cdot \sqrt{\frac{C_0 C_1}{C_0 + C_1} L_1}}$$

2

quality factor:

$$Q = \frac{1}{2\pi f_s R_1 C_1}$$

3

A very important factor in practice is the ratio:

$$r = \frac{C_0}{C_1}$$

4

This ratio effectively determines the sensitivity of crystal frequency to changes in external circuit parameters. Depending on the dimensions and shape of the crystal blanks the value "r" is approximately 200 for fundamental mode AT-crystals above 10 MHz (HC49/U) and 250 to 280 for low frequency fundamentals where the crystal blank is partially or fully contoured. The ratio for overtone crystals increases roughly in proportion to the square of the overtone order. (n = order of overtone).

$$r_n = r \cdot n^2$$

5

$$C_1 = \frac{C_0}{r n^2}$$

6

The pulling sensitivity is greatest for higher frequency fundamental mode crystals.

Quartz Crystal Theory

Why we ask you for load capacitance

Many practical oscillator circuits make use of load capacitor C_L in series or parallel to the crystal. The presence of load capacitor shifts the working frequency of the crystal by an amount depending upon the value of C_L and the value of C_0 and C_1 . The fig. 9 show the series and parallel connections respectively.

- C_L parallel to the crystal: resonance frequency f_r is not affected but the antiresonance f_a shifts down to the frequency f_L
- C_L in series to the crystal: f_a is unaffected but f_r moves up to a frequency f_L , the resistance R_L is higher than R_1
- the value of f_L can be easily obtained:

$$f_L = f_r + f_r \frac{C_1}{2(C_0 + C_L)}$$

7

$$\frac{\Delta f}{f} = \frac{f_L - f_r}{f_r} = \frac{C_1}{2(C_0 + C_L)}$$

8

$$R_L = R_1 \left(1 + \frac{C_0}{C_L} \right)^2$$

9

A standard oscillator with C_L parallel to the crystal is shown in fig. 10. The total capacitance external to the crystal is called load capacitance. The crystal manufacturer needs to know the value of C_L in order to adjust to the specified frequency.

The load capacitance is given by:

$$C_L = \frac{C_{X1} C_{X2}}{C_{X1} + C_{X2}} + C_{stray}$$

10

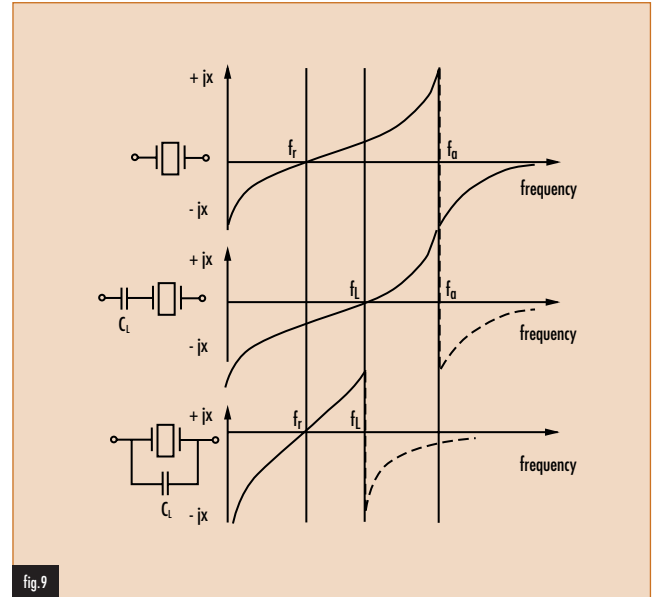

fig.9

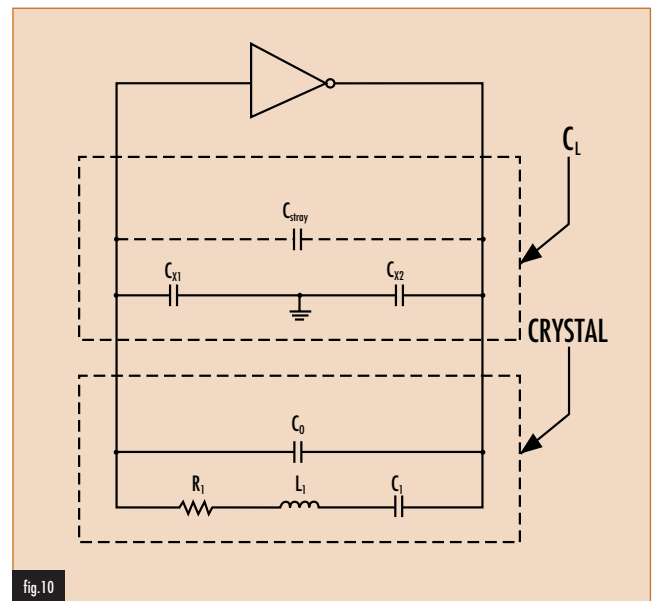

fig.10

Quartz Crystal Theory

Pulling sensitivity

The sensitivity of the working frequency to small changes in C_L is given by:

$$S = \frac{d \left(\frac{\Delta f}{f_r} \right)}{d C_L} = - \frac{C_1}{2 (C_0 + C_L)^2}$$

11 • (see also formula 8)

This formula shows the direct dependence of "S" to C_L . For high frequency crystals of fundamental modes "S" can be higher than -20 ppm/pF especially for low C_L values (fig.11). For high over-tone orders the sensitivity is lower than for fundamental mode units, because of much lower typical C_L values.

The pulling range between two load capacitance values is given by:

$$D_{L1/L2} = \frac{f_{L1} - f_{L2}}{f} = \frac{C_1 (C_{L2} - C_{L1})}{2 (C_0 + C_{L1}) (C_0 + C_{L2})}$$

12

Drive level

When ordering the crystals the customer should specify the operating drive level required. The crystals can be adjusted in the manufacturing process to the required drive level and start up problems under lowest drive levels are eliminated. A drive level of 100µW is recommended for all oscillator circuits. In a positive (inductive) reactance oscillator the power dissipation can be approximated as:

$$P = I^2 R_L \quad R_L = R_1 \left(1 + \frac{C_0}{C_L} \right)^2$$

13

$$P = \frac{U^2}{R_1 \left(1 + \frac{C_0}{C_L} \right)^2}$$

14

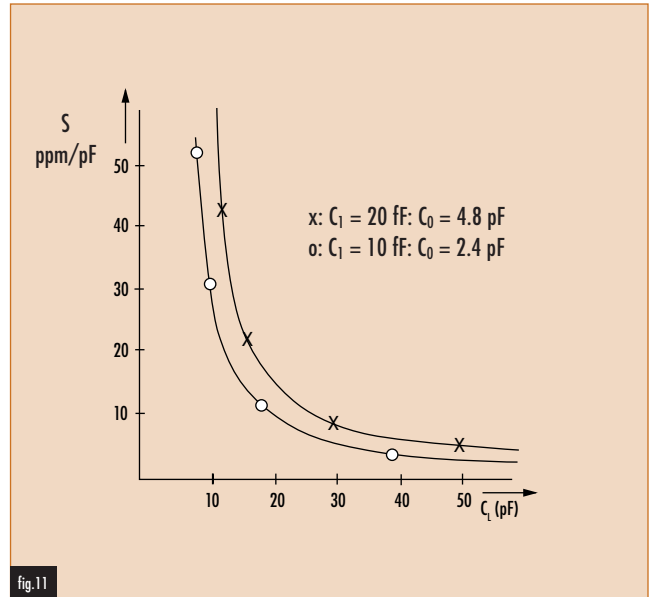

Aging

Aging is defined as frequency changes over a certain period of time. The aging test is carried out according to DIN 45103. The common aging rate for commercial crystals is:

$$\frac{\Delta f}{f} \leq \pm 5 \text{ ppm / year}$$

15

Spurious responses

Spurious responses are other resonant frequencies that are present near the nominal operating frequency. The frequency difference between the operating frequency and the spurious responses are normally quite small. For special applications it is sometimes necessary to damp down these responses with calculated C_L values. The damping figure is given in dB.

$$a_{NW} = 20 \log \frac{R_{NW}}{R_1}$$

25

Quartz Crystal Theory

Measurement methods

Active method: (oscillator)

Quartz crystal parameters: resonant frequency f_r , motional resistance R_1 , motional capacitance C_1 , motional inductance L_1 and load resonance f_L can be measured with the active method. The active measurement method is fast and inexpensive. Because of accuracy limitations this method is not recommended for tolerance requirements better than ± 10 ppm.

$$C_1 = \frac{2(f_L - f_r)}{f_r} (C_0 + C_L)$$

16

$$L_1 = \frac{1}{4\pi^2 f_r^2 C_1}$$

17

$$R_L = R_1 \left(1 + \frac{C_0}{C_L} \right)^2$$

18

Passive method: (double π - network)

This method (fig.12) is described in DIN 45105 part 7, IEC pub. 302. With a shorting metal blank or a non-inductive reference resistor in the π -network, a phase meter is adjusted to zero phase condition between U_2 and U_1 . U_2 can then be calculated for the value of desired drive level:

The crystal unit can now be put into a π -network. The frequency is then adjusted to produce zero phase. This frequency is by definition the resonance frequency of the crystal unit. The value of motional resistance can be determined by the formula below.
 U_{2K} : voltage short circuit; U_2 : voltage on the crystal; U_1 : reference voltage (measured).

$$P_C = R_1 \times U_2^2 \times 4.79 \times 10^{-2}$$

19

$$R_1 = 25 \times \left[K \frac{U_{2K}}{U_{1K}} - 1 \right]$$

20

$$K = \frac{U_{2K}}{U_{1K}} \approx 1$$

21

$$C_1 = \frac{\Delta f_{(\pm\varphi)}}{2\pi f_r^2 R_{\text{eff}} \tan \varphi}$$

22

$$R_{\text{eff}} = R_1 + 25$$

23

$$L_1 = \frac{R_{\text{eff}}}{2\pi \Delta f_{(\pm\varphi)}} \tan \varphi$$

24

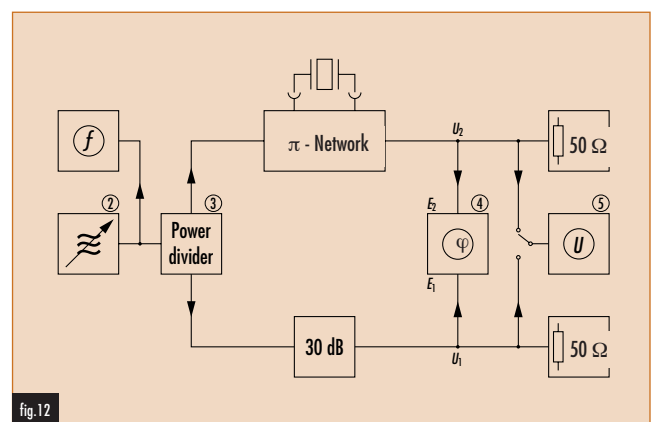

fig.12